

RAB30 Series

Four-pipe Fan Coil Room Thermostat



RAB30.1U

Description Two-wire, gas diaphragm-based fan coil room thermostat with heating and/or cooling sequence for four-pipe fan coil applications.

- Features**
- Manual, three-speed fan switch
 - Fan release function
 - Dual setpoint temperature scale
 - Two-point control algorithm (On/Off)
 - Manual changeover selector
 - 24 to 120 Vac, 277 Vac operating voltage
 - Two mounting styles: electrical wall box and drywall
 - Wall plate adapter (ARG70) included with electrical wall box mount styles

Application The RAB30... is used in heating or cooling systems to maintain the selected room temperature.

Typically used in commercial, high-rise and light industrial buildings in conjunction with:

- Zone valves
- Thermal valves
- Fans

Product Numbers See Table 1.

Accessory ARG70 Wall box adapter

Warning/Caution Notations

WARNING:		Personal injury, or loss of life may occur if you do not perform a procedure as specified.
-----------------	--	--

Table 1. Product Numbers.

Mounting Style	Product Number	Description
Electrical Wall Box (with wall box adapter)	RAB30.1UW	Heating and/or cooling; degrees Fahrenheit and Celsius; four-pipe manual changeover; fan only function
Drywall	RAB30.1U	Heating and/or cooling; degrees Fahrenheit and Celsius; four-pipe manual changeover; fan only function

Technical Design

The RAB30... fan coil room thermostat is based on a two-wire, gas diaphragm technology.

Operation

When the heating mode is manually selected, and the room temperature falls below the selected setpoint, the heating contact is closed.



Heating Mode

Cooling Mode

When the cooling mode is manually selected, and the room temperature rises over the selected setpoint, the cooling contact is closed.



Fan Speed

The fan control speed can be controlled two ways:

- Manually, using the three-speed fan switch on the thermostat cover for continuous operation.  (Low),  (Medium),  (High).
- Automatically, by switching to the selected fan speed using the thermostat for controlled operation. Prior to commissioning, the jumper position corresponding to the thermostat function must be selected.

Fan Release Setting

There are two jumper position choices on the printed circuit board:

- Jumper SR1  Selected fan speed as continuous operation
- Jumper SR2  Auto Fan is switched at the same time as the cooling or heating valve, depending on the switch position.

Ventilation

When the ventilation function () is selected (RAB30.1.. only), the heating and cooling contacts are always open and the fan works at the selected speed.

Changeover

The heating/cooling mode can be selected with a switch located on the front of the controller (changeover switch).

Adjustments

The required temperature can be selected by a rotating setpoint adjuster at the front of the thermostat. High and low limit stops can be engaged to limit temperature range.

Specifications	Operating voltage	24 to 120 Vac, 277 Vac
	Frequency	50/60 Hz
	Setpoint adjustment range	50°F to 85°F (10°C to 30°C)
	Setpoint limit stops	Adjustable
	Switching differential (SD)	≤1.8°F (1°C), fixed
	Switch rating	6A RES, 3.5A FLA, 12A LRA
	Switch action	Single-Pole, Double-Throw (SPDT)
	Weight	5 oz. (0.14 kg)
	Dimensions	3.80 × 4.45 × 1.68 (96.4 × 113.1 × 42.8 mm)
	Color	Ivory white with gray selector knobs
Ambient Conditions	Operation - Climatic conditions	
	Temperature	32°F to 122°F (0°C to 50°C)
	Relative humidity	<95%
	Transport/Storage - Climatic conditions	
	Temperature	-4°F to 122°F (-20°C to 50°C)
	Relative humidity	<95%
Housing	Material	Plastic
	Enclosure rating	NEMA1
	Bellows	Environmentally-friendly gas
Wiring	Screw terminals for wires of	2 × 16 AWG or 1 × 14 AWG minimum 20 AWG
Agency Certification		Conforms to CE requirements UL listed to 873 (E35918) cUL listed to Canadian standard C22.2 No. 24-93

Table 2. Control Valves.

Part Number	Description	Technical Instructions
SFA71U	24V NC	155-521
SFA11U	120V NC	
SFA208V/25	208V NC	
SFA277V/25	277V NC	
FTA71	24V NC	155-109
599 Series Zone Valves	Two-way Three-way	155-320P25

Mounting

Locate the unit where the air temperature can be sensed as accurately as possible. Do not mount in direct sunlight or near other heat or refrigeration sources.

Mounting height is approximately 60 inches (1.5 m) above the floor.

The unit can be fitted to most commercially available recessed conduit boxes or directly on the wall.

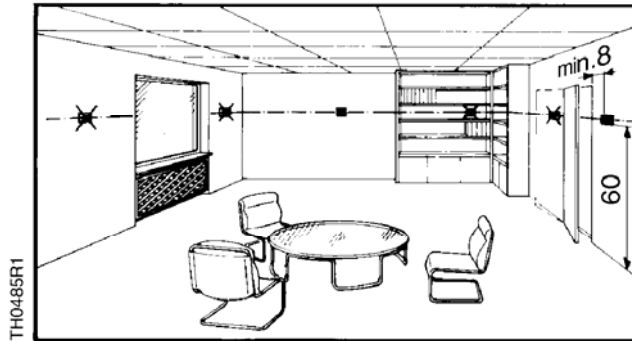

**Figure 1. Recommended Mounting Locations.
(Dimensions in Inches)**



WARNING:

1. This unit can be installed by authorized personnel only.
2. The unit must be de-energized and the operating voltage checked before opening.

- An ARG70 wall plate adapter (provided with electrical wall box mount styles) must be used to mount to a 2 x 4-inch or 4 x 4-inch electrical wall box.
- An ARG70 wall plate adapter must be used to meet UL and cUL requirements.
- The thermostat must be mounted on a flat wall.
- All local electrical regulations must be complied with.
- If there are radiator valves in the room, set them to their fully open position.

Setpoint Limit Stops Adjustment

To set limit stops, remove gray tabs located on the setpoint knob and position high and low stops around the perimeter of knob as required. Each position on the setpoint dial is 1.8°F (1°C). See Figure 2.

Installation

Required Tools

- Small, flat-blade screwdriver
- 1/4-inch drill bit
- Drill motor
- Small mallet
- Pencil

Drywall Mounting

1. Loosen the two screws at the bottom of thermostat.
2. Lift the bottom of the thermostat cover from the thermostat base and push up to remove cover.
3. Remove sub-base from back of thermostat.
4. Using the sub-base (packed with thermostat) as a template, mark the hole locations with a pencil.
5. Drill two 1/4-inch diameter holes for plastic wall anchors (provided).
6. Using a mallet, tap in the plastic wall anchors flush with wall.
7. Pull the wiring through the opening in the upper portion of the sub-base.
8. Level mounting plate.
9. Using two wood screws provided, fasten sub-base to wall. Thermostat is not position sensitive.
10. Pull the wiring through the sub-base.
11. Position thermostat housing over the two mounting lugs located at the top of the sub-base, and press down on cover until bottom lugs snap in place.
12. Terminate wires per wiring instructions on the inside of thermostat cover.

Optional: To set limit stops, remove gray tabs located on the setpoint knob and position high and low stops around perimeter of knob as required. See Figure 2.

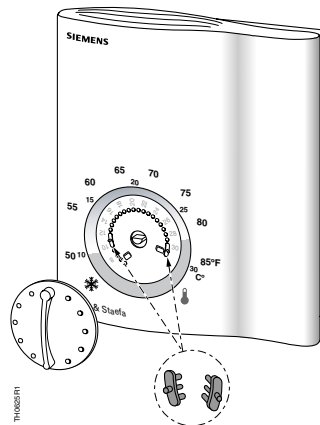

Figure 2. Setpoint Limit Stops.

13. Place all thermostat switches in the “down” position to allow cover switch sliders to fit over the switches.
14. Insert the top of the thermostat cover into the slots located on the top of the thermostat and press down.
15. Tighten the two screws at the bottom of the thermostat.
16. Return selector switches to the normal position. Adjust setpoint dial to desired setting.

The installation is now complete.

4 x 4-inch Electrical Wall Box Mounting

An ARG70 wall plate adapter (provided with electrical wall box mount styles) is required to mount an RAB... thermostat to a 4 x 4-inch electrical wall box.

1. Loosen the two screws at the bottom of thermostat.
2. Lift the bottom of the thermostat cover from the thermostat base and push up to remove cover.
3. Using the four screws provided, fasten wall box adapter (3) to plaster ring (2), supplied by others.
4. Pull wires through plaster ring (2).
5. Flex adapter mask (4) and snap in place inside wall box adapter (3).
6. Fasten sub-base (5), included with thermostat, to wall box adapter assembly (3) and (4) with the two screws provided.
7. Follow *Drywall Mounting Steps 7 through 16*.

The installation is now complete.

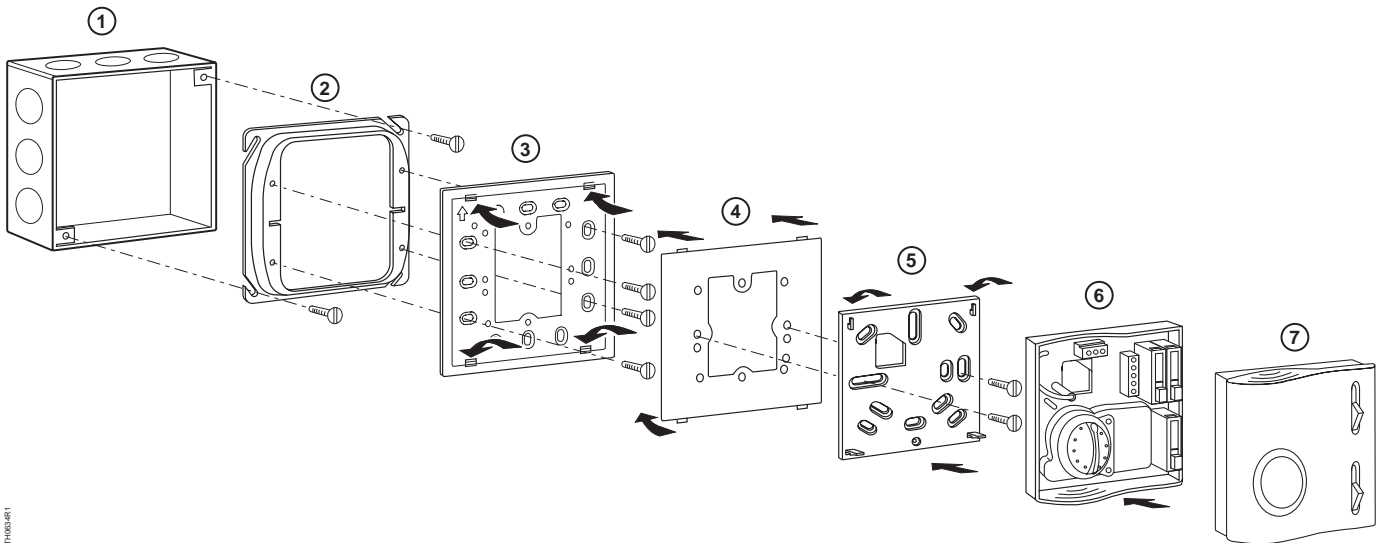

Figure 3. 4 x 4-inch Electrical Wall Box Installation.

- | | |
|-----------------------|--------------------|
| 1 Electrical wall box | 5 Sub-base |
| 2 Plaster ring | 6 Thermostat base |
| 3 Wall box adapter * | 7 Thermostat cover |
| 4 * Adapter mask | |

* Included with ARG70

2 x 4-inch Electrical Wall Box Mounting

An ARG70 wall plate adapter (provided with electrical wall box mount styles) is required to mount an RAB... thermostat to a 2 x 4-inch electrical wall box. The ARG70 wall plate adapter is included with electrical wall box mount models.

1. Loosen the two screws at the bottom of thermostat.
2. Lift the bottom of the thermostat cover from the thermostat base and push up to remove cover.
3. Using the two screws provided, fasten wall box adapter (3) to plaster ring (2), supplied by others.
4. Pull wires through plaster ring (2).
5. Flex adapter mask (4) and snap in place inside wall box adapter (3).
6. Fasten sub-base (5), included with thermostat, to wall box adapter assembly (3) and (4) with the two screws provided.
7. Follow *Drywall Mounting* Steps 7 through 16.

The installation is now complete.

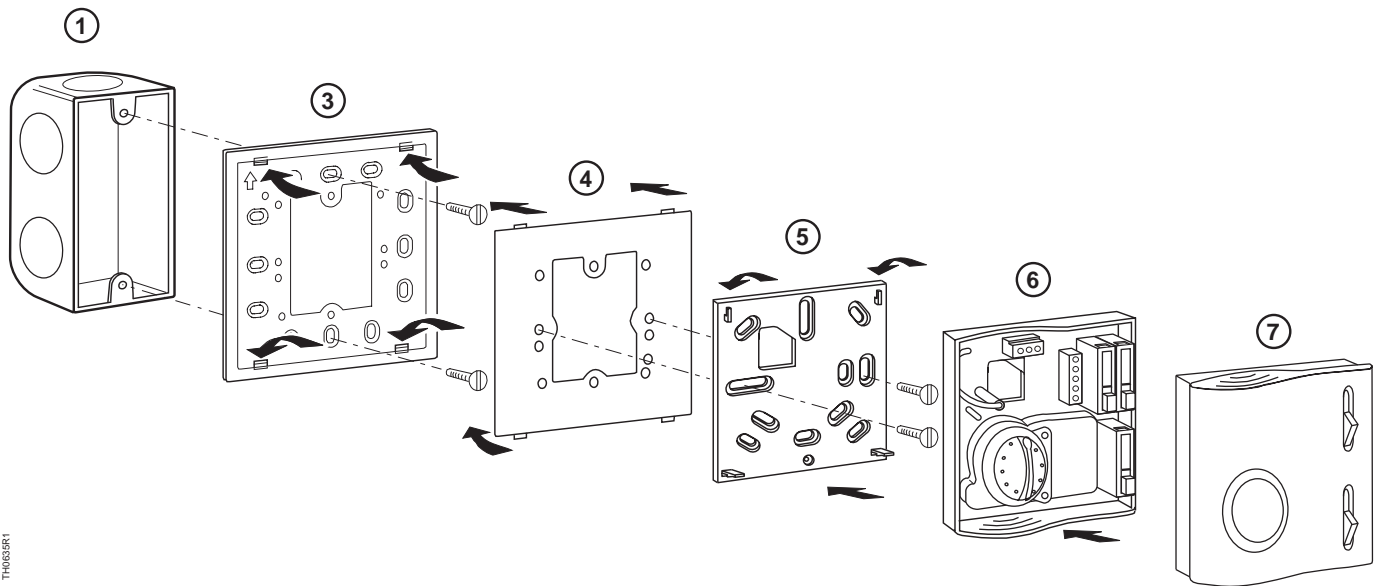

Figure 4. 2 x 4-inch Electrical Wall Box Installation.

- | | |
|-----------------------|--------------------|
| 1 Electrical wall box | 5 Sub-base |
| 3 Wall box adapter * | 6 Thermostat base |
| 4 Adapter mask * | 7 Thermostat cover |

* Included with ARG70

Maintenance

The room thermostat is completely maintenance-free. If inoperable, replace entire unit.



WARNING:

High voltage. Disconnect power before servicing. Metal part is not grounded.

Diagrams

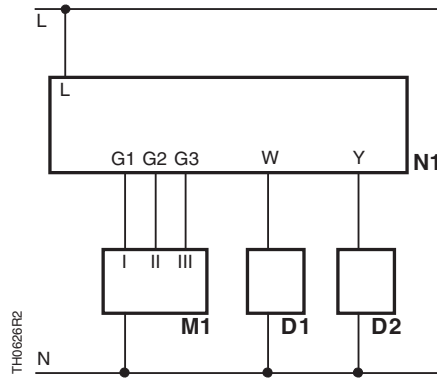

- D1 Heating valve
- D2 Cooling valve
- G1 Control output fan speed I (Low)
- G2 Control output fan speed II (Medium)
- G3 Control output fan speed III (High)
- L Operating voltage
- M1 3-speed fan
- N Neutral
- N1 Room thermostat
- W Control output heating
- Y Control output cooling

Figure 5. Wiring.

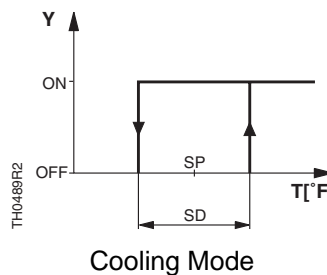
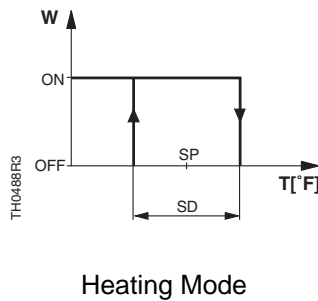

- T Room temperature
- SD Switching differential
- SP Room temperature setpoint
- W Valve output signal heating
- Y Valve output signal cooling

Figure 6. Operating.

Dimensions

Dimensions in inches (millimeters)

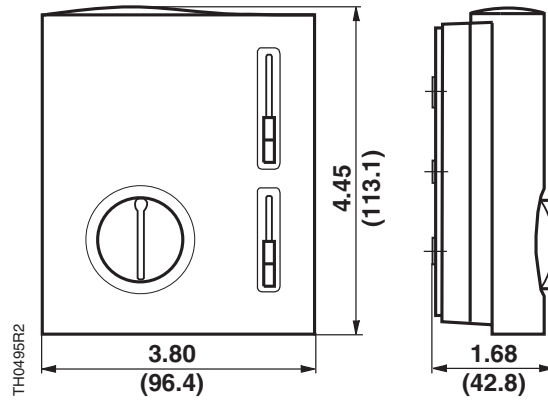

Figure 7. RAB30... Unit.

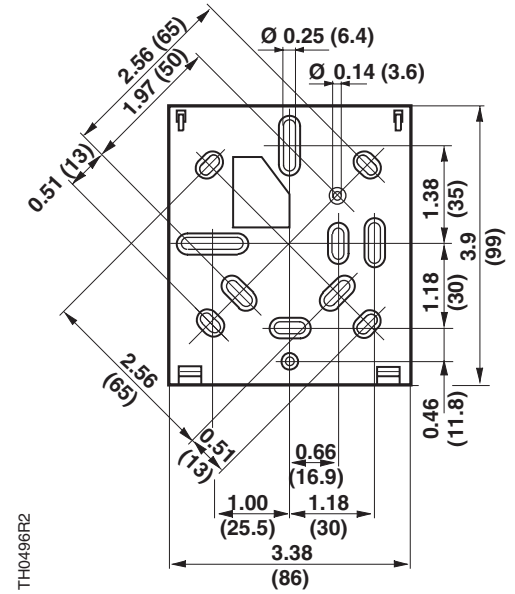

Figure 8. Base Plate.

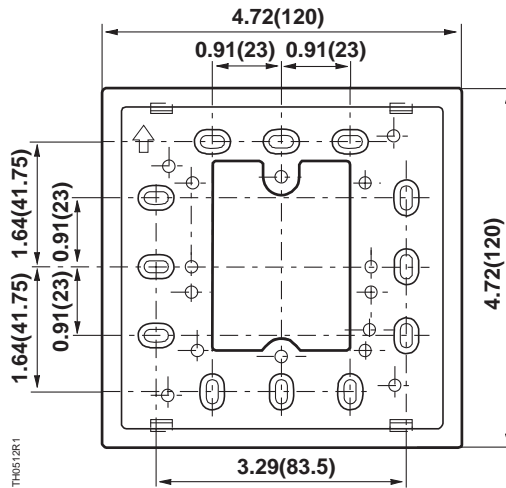
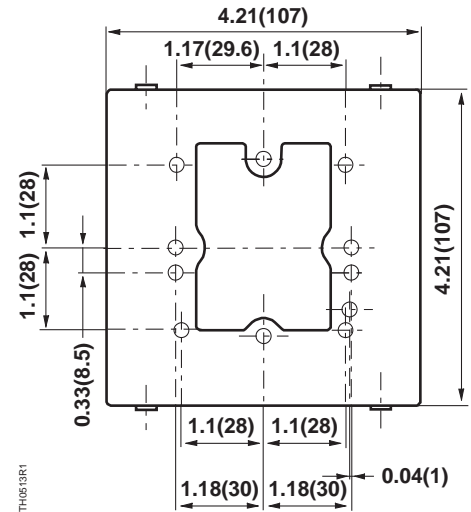

Figure 9. ARG70.



Information in this publication is based on current specifications. The company reserves the right to make changes in specifications and models as design improvements are introduced. Product or company names mentioned herein may be the trademarks of their respective owners.
 © 2007 Siemens Building Technologies, Inc.