

Technical description

Application:

Heating and cooling systems.

Functions:

Differential pressure control
Adjustable Δp
Measuring points
Shut-off

Pressure class:

PN 16

Max. differential pressure (Δp_V):

350 kPa

Temperature:

Max. working temperature: 80°C
Min. working temperature: -10°C

Setting range:

20-80 kPa resp 40-160 kPa.

Materials:

Valve body: Cast iron EN-GJL-250 (GG 25)
Bonnet: AMETAL®
O-rings: EDPM rubber
Seat seal: Plug with EPDM O-ring
Membrane: Reinforced EPDM rubber
Spring: Stainless steel
Handwheel: Polyamide

AMETAL® is the dezincification resistant alloy of TA.

Surface treatment:

Valve body: Epoxy painting.

Marking:

Body: TA, PN 16, DN, CE, 250 CI, flow arrow and casting date (year, month, day).
Bonnet and handwheel: Label with STAP, DN, Δp_L 20-80 resp 40-160 kPa and bar code.

Face to face dimensions:

ISO 5752 series 1, BS 2080

Flanges:

ISO 7005-2.

STAP DN 65-100

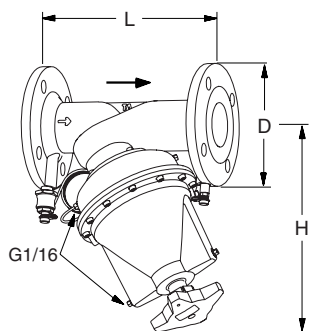

20-80 kPa

TA No	DN	Number of bolt holes	D	L	H	Kv _m
52 265-065	65	4	185	290	414	36
52 265-080	80	8	200	310	436	55
52 265-090	100	8	220	350	460	110

40-160 kPa

TA No	DN	Number of bolt holes	D	L	H	Kv _m
52 265-165	65	4	185	290	414	36
52 265-180	80	8	200	310	436	55
52 265-190	100	8	220	350	460	110

1 m capillary pipe and transition nipple with shut-off are included.

➔ = Flow direction

Kv_m = m³/h at a pressure drop of 1 bar and opening corresponding to the p-band (-25%).

Operating instruction

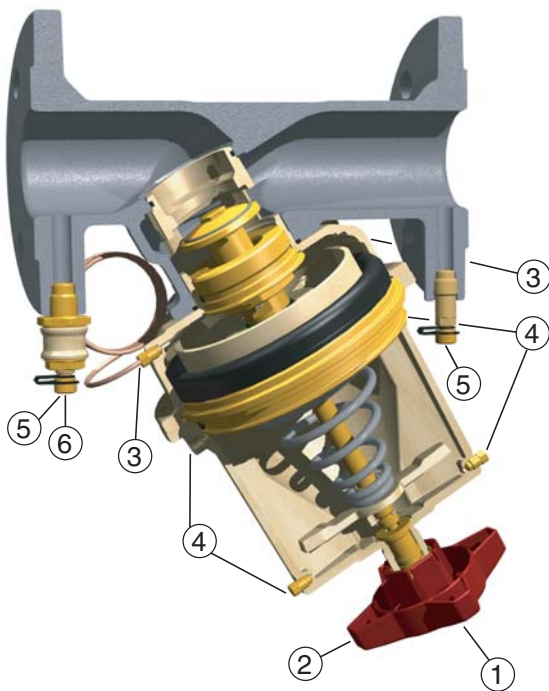

1. Setting Δp_L (5 mm allen key)
2. Shut-off
3. Connection capillary pipe, low pressure.
4. Venting. Connection measuring point STAP. Connection capillary pipe, high pressure.
5. Measuring point
6. Opening/closing of measure signal for the low pressure side

Measuring point

Remove the cover and then insert the probe through the self-sealed testpoint.

Measuring point STAP (accessory) can be connected to the venting if the STAF valve is out of reach for measuring of differential pressure.

When extending the capillary pipe, use e.g. 6 mm copper pipe and extension kit (accessory).

Note! The supplied capillary pipe must be included.

Installation

Note! The STAF must be placed in the return pipe and with correct flow direction.

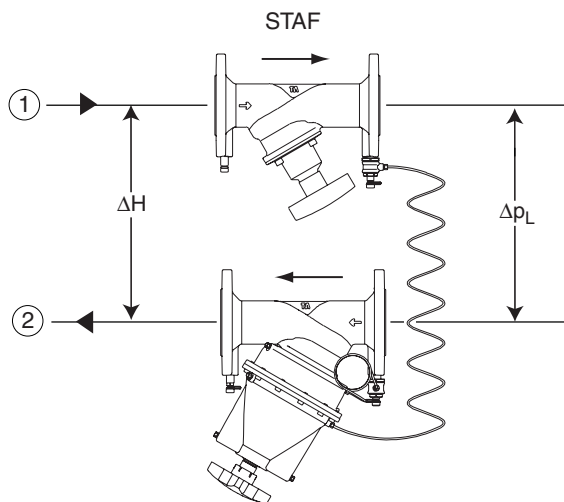

1. Inlet
2. Return

For installation examples, see catalogue leaflet Applications STAF or Handbook No 4 - Hydronic balancing with differential pressure controllers.

STAF see catalogue leaflet STAF, STAF-SG,....

Sizing of the valve

1. Select the desired Δp_L in the tables or diagrams.
2. Select the same size of the valve as the pipe.
3. Check that the desired flow is **smaller** than the specified q_{max} . If not, select the nearest bigger dimension, alternatively a bigger Δp_L .

Working range

The tables are valid for:

$\Delta H \geq 2 \times \Delta p_L$, but the valve works properly between $\Delta H \sim 1,5 \times \Delta p_L$ to $350 \text{ kPa} + \Delta p_L$.

20-80 kPa (52 265-065, -080, -090)

DN	Δp_L (kPa)														
	20			30			40			50			60		
	q_{\min}	q_{nom}	q_{\max}	q_{\min}	q_{nom}	q_{\max}	q_{\min}	q_{nom}	q_{\max}	q_{\min}	q_{nom}	q_{\max}	q_{\min}	q_{nom}	q_{\max}
65	630	11000	15900	770	13500	19500	890	15600	22500	1000	17400	25100	1090	19100	27500
80	980	16840	24370	1200	20600	29800	1390	23800	34500	1550	26600	38500	1700	29200	42200
100	1950	33820	48670	2390	41400	59600	2760	47800	68800	3080	53500	77000	3380	58600	84300

DN	Δp_L (kPa)					
	70			80		
	q_{\min}	q_{nom}	q_{\max}	q_{\min}	q_{nom}	q_{\max}
65	1180	20600	29700	1260	22000	31800
80	1830	31500	45600	1960	33700	48700
100	3650	63300	91100	3900	67600	97300

40-160 kPa (52 265-165, -180, -190)

DN	Δp_L (kPa)														
	40			50			60			70			80		
	q_{\min}	q_{nom}	q_{\max}	q_{\min}	q_{nom}	q_{\max}	q_{\min}	q_{nom}	q_{\max}	q_{\min}	q_{nom}	q_{\max}	q_{\min}	q_{nom}	q_{\max}
65	890	15900	23000	1000	17800	25700	1090	19500	28200	1180	21000	30400	1260	22500	32500
80	1400	24370	35000	1570	27200	39100	1710	29800	42900	1850	32200	46300	1980	34500	49500
100	2800	48670	70000	3130	54400	78300	3430	59600	85700	3700	64400	92600	3960	68800	99000

DN	Δp_L (kPa)														
	90			100			110			120			130		
	q_{\min}	q_{nom}	q_{\max}	q_{\min}	q_{nom}	q_{\max}	q_{\min}	q_{nom}	q_{\max}	q_{\min}	q_{nom}	q_{\max}	q_{\min}	q_{nom}	q_{\max}
65	1340	23900	34500	1410	25100	36400	1480	26400	38100	1540	27500	39800	1600	28700	41500
80	2100	36600	52500	2210	38500	55300	2320	40400	58000	2420	42200	60600	2520	43900	63100
100	4200	73000	105000	4430	77000	111000	4640	80700	116000	4850	84300	121000	5050	87700	126000

DN	Δp_L (kPa)								
	140			150			160		
	q_{\min}	q_{nom}	q_{\max}	q_{\min}	q_{nom}	q_{\max}	q_{\min}	q_{nom}	q_{\max}
65	1670	29700	43000	1720	30800	44500	1780	31800	46000
80	2620	45600	65500	2710	47200	67800	2800	48700	70000
100	5240	91100	131000	5420	94200	136000	5600	97300	140000

	Kv_{\min}	Kv_{nom}	Kv_m
DN 65	1,4	25	36
DN 80	2,2	38	55
DN 100	4,4	77	110

Note! The flow in the circuit is determined by its resistance, i.e. $Kv_C: q_C = Kv_C \sqrt{\Delta p_L}$

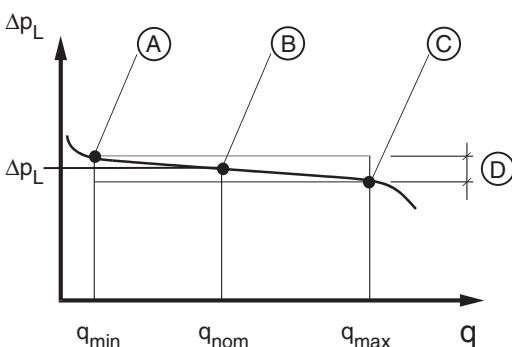

- A. Kv_{\min}
- B. Kv_{nom} . Delivery setting $\Delta p_L = 20 \text{ kPa}$ respectively 40 kPa
- C. Kv_m
- D. Working range $\Delta p_L \pm 25\%$

Diagram

The maximum flows in the diagram correspond to a pressure drop of 500 Pa/m for the concerned pipe.

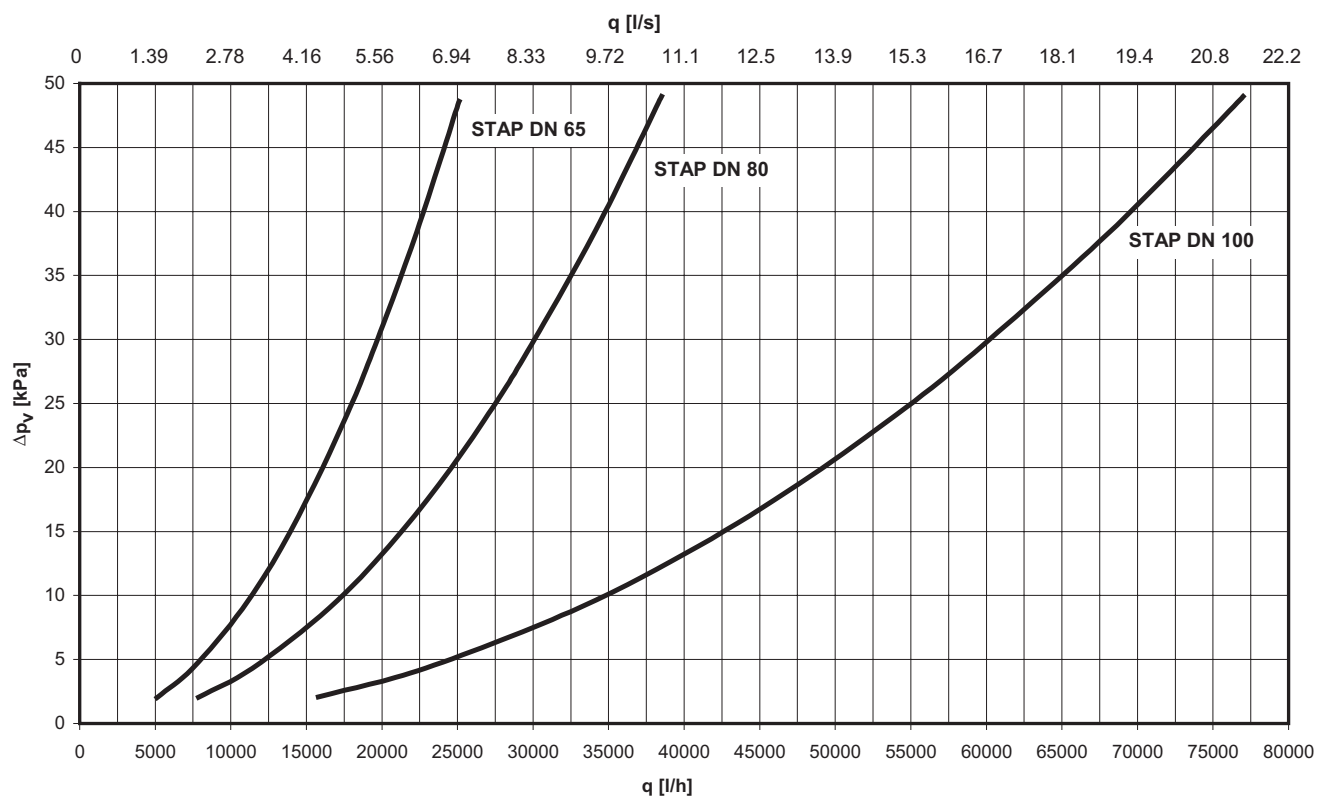

Accessories

Measuring point STAP

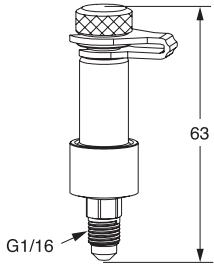

TA No
52 265-205

Measuring point, two-way

For connection of capillary pipe while permitting simultaneous use of TA-CBI

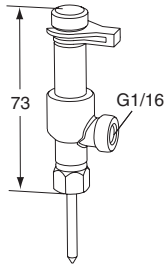

TA No
52 179-200

Extension kit for capillary pipe

Complete with connections for 6 mm pipe

TA No
52 265-212

Capillary pipe connection with shut-off

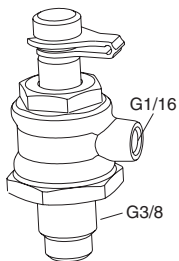

TA No
52 265-206

Capillary pipe

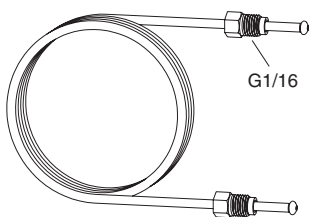

TA No	L
52 265-301	1 m

Plug Venting

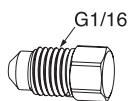

TA No
52 265-302 5 pcs/package

Tour & Andersson retains the right to make changes to its products and specifications without prior notice.