

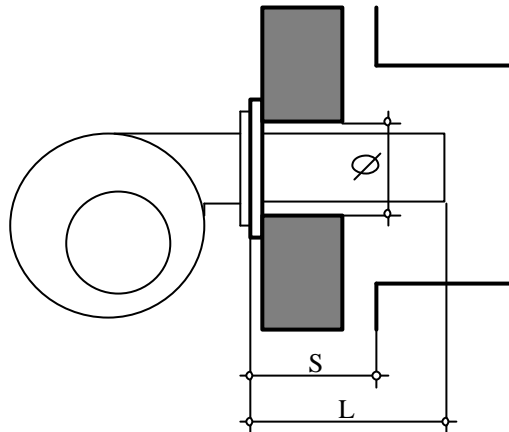

**TECHNICAL DATA FOR BURNER MATCHING FOR BOILERS Mod.:**  
**BHP**



Boiler model	Nominal capacity	Furnace capacity	Furnace pressure	Cement hole on front door	Distance from furnace	Head lenght min/max	Type	Intern. Furnace diameter mm	Intern. Furnace lenght mm
	Kw	kW	mbar	Ø mm	S mm	L mm			
BHP 140	97	108	1,5	150	240	320 / 400	<b>Flame reverse</b>	432	1110
BHP 200	138	153	2,5	150	240	320 / 400		432	1110
BHP 300	208	231	3,0	170	240	320 / 400		480	1409
BHP 400	277	308	3,5	170	240	320 / 400		480	1409
BHP 500	346	384	4,2	200	240	320 / 400		576	1659
BHP 700	485	539	4,5	200	240	320 / 400		576	1659
BHP 800	554	616	5,0	250	240	320 / 400		626	1660
BHP 1000	692	769	6,0	250	240	320 / 400		626	1860
BHP 1250	865	961	6,5	300	240	320 / 400		724	1860
BHP 1500	1038	1154	6,8	300	240	320 / 400		724	2110
BHP 1750	1212	1347	7,0	300	250	350 / 450		724	2405
BHP 2000	1385	1539	7,0	300	250	350 / 450		822	2340
BHP 2500	1731	1923	8,0	300	250	350 / 450		872	2660
BHP 3000	2077	2308	8,2	340	250	350 / 450		940	2660
BHP 3500	2423	2692	9,0	340	250	350 / 450		940	2860
BHP 4000	2769	3077	10,0	370	270	370 / 470		1064	3082

